

**NOTES:**

- 1) Reel Material: 1.2 mm 1,0037 (S235JR) ST DKP
- 2) Reel Color Code: Ral 7000
- 3) Cable Length: 150mt.
- 4) Cable End A: 900-0010
- 5) Cable End B: 900-0010
- 6) Cable Type: Mobile Field Cable 5,6mm, 4x9/125µm G.652.D/G.657.A1, Tight Tube
- 7) C: Reel Stand
- 8) D: Reel Handle

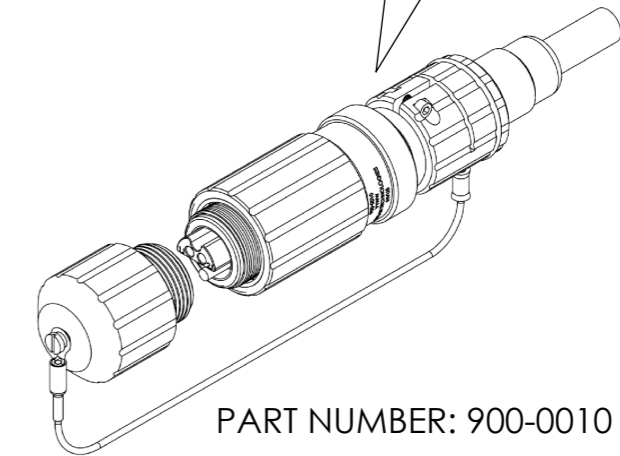
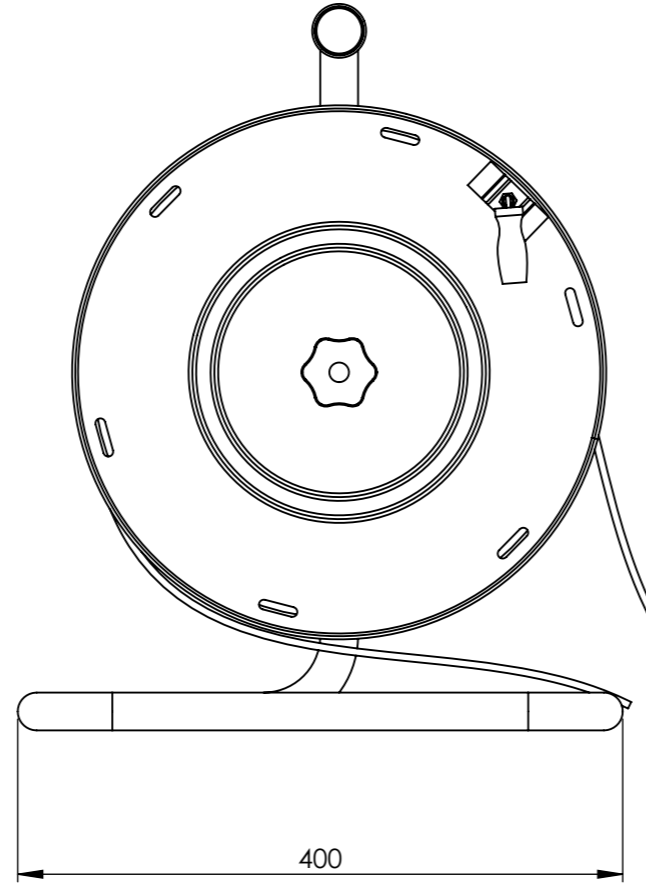
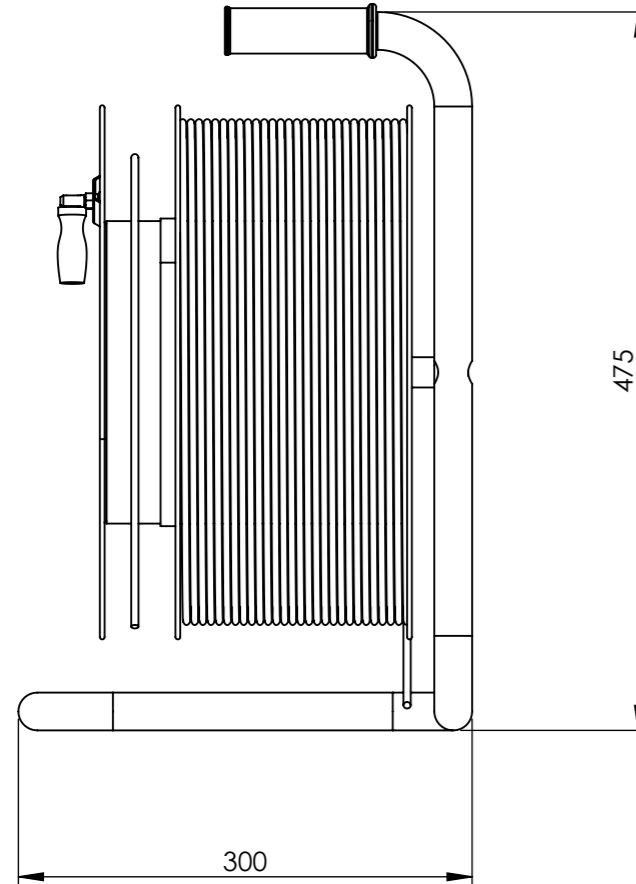
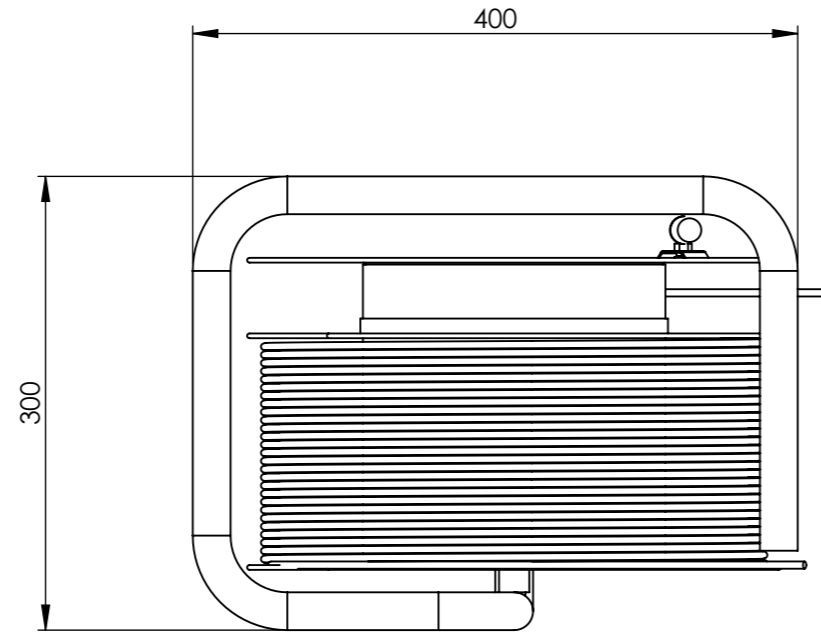

**ORİNAL PARÇA/REF.NO.:MT02623**

TOLERANCES	DRAWN BY	5038	2.04.2019	<b>SAMM TEKNOLOJİ A.Ş.</b>			
.00 ± -	CHECKED BY	1793	2.05.2019	GOSB İhsandede Cd. 800. Sok			
.000 ± -	APPROVED BY	1793	2.05.2019	No: 802, 41400 Gebze-Kocaeli			
.0000 ± -	<b>REEL CONNECTION BOX</b>			PROJECT NUMBER	<b>2019.009.1.002</b>		
ANGLES ± -				REVISION	0		
ALL DIMENSIONS ARE IN MM. ALL DIMENSIONS APPLY AFTER PLATING				SCALE	1:5		
				SHEET NUMBER	1 OF 1		

PROPRIETARY INFORMATION THIS DOCUMENT CONTAINS PROPRIETARY INFORMATION FOR MANUFACTURING FOR ANYONE OTHER THAN SAMM TEKNOLOJİ AND IS DELIVERED ON THE EXPRESSED CONDITIONS THAT IT IS NOT TO BE DISCLOSED OR REPRODUCED IN WHOLE OR PART, OR USED TECHNOLOGIES WITHOUT ITS WRITTEN CONSENT AND THAT NO RIGHT IS GRANTED TO DISCLOSE OR SOUSE ANY INFORMATION CONTAINED IN SAID DOCUMENT.